

FILTRI SERIE SPIN-ON

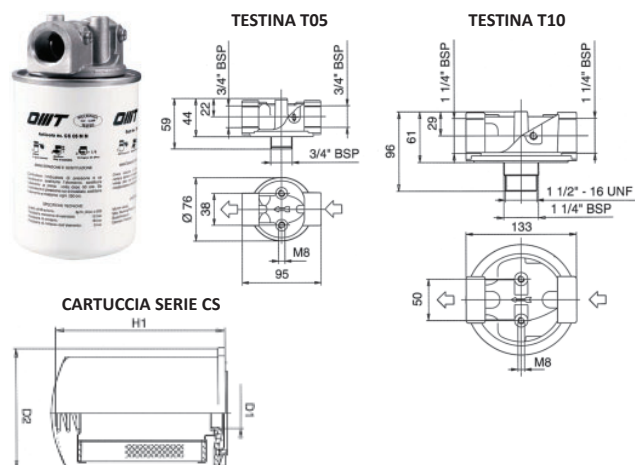

FILTRO CON BY-PASS									
Testina in ritorno		Testina in aspirazione			Cartuccia				
Codice	€	Codice	€	D1	D2	H1	µm	Codice	€
T05VOR	48,622	T05VOA	48,622	3/4"	98	145	10	CS05ANA	39,432
							25	CS05BNA	39,432
							60	CS05CNA	72,345
T05VOR	48,622	T05VOA	48,622	3/4"	98	190	10	CS06ANA	62,010
							25	CS06BNA	62,010
							60	CS06CNA	91,489
T10VOR	60,484	T10VOA	60,484	1.1/4"	132	180	10	CS10ANA	66,589
							25	CS10BNA	66,589
							60	CS10CNA	104,876
T10VOR	60,484	T10VOA	60,484	1.1/4"	132	226	10	CS15ANA	83,825
							25	CS15BNA	83,825
							60	CS15CNA	139,729

FILTRI IN ASPIRAZIONE SERIE SF

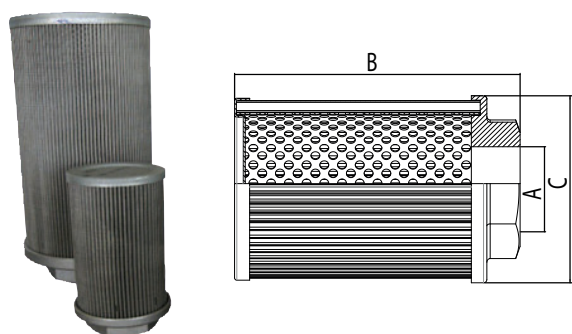

Attacco in alluminio
Fondello in acciaio zincato
Valvole di by-pass in nylon

SF - CON ATTACCO IN LEGA DI ALLUMINIO							
Tipo	L/min.	A	B	C	µm	Codice	€
046A	10	3/8"	90	46	60	SF046A038GR060	38,580
					90	SF046A038GR090	27,854
					60	SF046A012GR060	38,580
046B	14	1/2"	90	46	60	SF046A012GR090	27,854
					60	SF046B012GR060	48,622
					90	SF046B012GR090	39,655
064A	14	1/2"	109	64	60	SF064A012GR060	45,022
					90	SF064A012GR090	33,129
					60	SF064A034GR060	45,022
086A	25	3/4"	109	64	90	SF064A034GR090	33,129
					60	SF086A100GR060	71,143
					90	SF086A100GR090	48,136
086A	45	1"	139	86	60	SF086A114GR060	71,143
					90	SF086A114GR090	48,136
					60	SF086A112GR060	71,143
086A	62	1.1/4"	139	86	90	SF086A112GR090	48,136
					60	SF086A112GR060	71,143
					90	SF086A112GR090	48,136
086A	90	1.1/2"	139	86	60	SF086A200GR060	71,143
					90	SF086A200GR090	48,136
086A	116	2"	139	86	60	SF086A200GR060	71,143
					90	SF086A200GR090	48,136

FILTRI OMTF

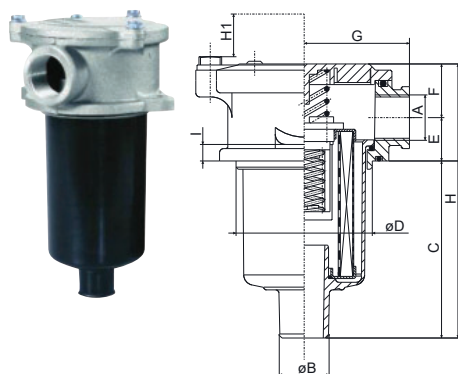

Serie	GRANDEZZA									CARTUCCIA			FILTRO COMPLETO		
	A	ØB	C	ØD	E	F	G	H	H1	I	µm	Codice	€	Codice	€
09	1/2"	24,5	85	66	21	26	50	132	110	8	25	CR091C25	19,716	OMTF091C25NA0	65,413
											60	CR091R60	27,889	OMTF091R60NA0	73,585
											90	CR091R90	25,790	OMTF091R90NA0	71,486
11	1/2"	30	92	86	29	34	67	155	130	10	25	CR111C25	22,292	OMTF111C25NA0	75,048
											60	CR111R60	36,061	OMTF111R60NA0	88,817
											90	CR111R90	29,288	OMTF111R90NA0	82,044
	3/4"	30	92	86	29	34	67	155	130	10	25	CR111C25	22,292	OMTF111C25NA1	75,048
											60	CR111R60	36,061	OMTF111R60NA1	88,817
											90	CR111R90	29,288	OMTF111R90NA1	82,044
11	1"	30	150	86	29	34	67	213	190	10	25	CR112C25	26,744	OMTF112C25NA1	83,984
											60	CR112R60	49,067	OMTF112R60NA1	106,307
											90	CR112R90	38,637	OMTF112R90NA1	95,877
	3/4"	30	92	86	29	34	67	155	130	10	25	CR111C25	22,292	OMTF111C25NA2	75,048
											60	CR111R60	36,061	OMTF111R60NA2	88,817
											90	CR111R90	29,288	OMTF111R90NA2	82,044
1"	30	150	86	29	34	67	213	190	10	25	CR112C25	26,744	OMTF112C25NA2	83,984	
										60	CR112R60	49,067	OMTF112R60NA2	106,307	
										90	CR112R90	38,637	OMTF112R90NA2	95,877	
17	1.1/4"	40	244	129	35	45	95	323	255	10	25	CR171C25	45,728	OMTF171C25NA1	155,375
											60	CR171R60	82,489	OMTF171R60NA1	192,136
											90	CR171R90	56,604	OMTF171R90NA1	166,250